

## **Section VIII. Sample Forms**

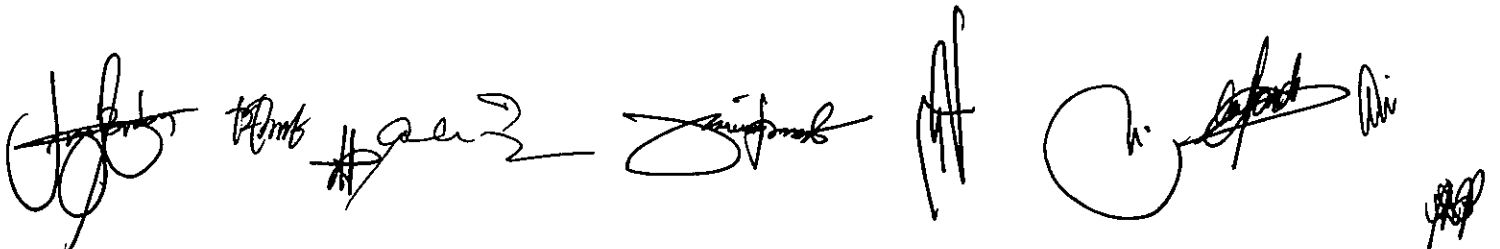

A series of handwritten signatures and initials in black ink, including a large stylized signature on the left, a signature with 'PAF' written above it, a signature with '2' written above it, a signature with 'Simpson' written above it, a signature with 'AF' written above it, a signature with 'ni' written above it, a signature with 'ni' written above it, and a small signature on the far right.

**G-EPS Platinum Certificate**

Republic of the Philippines  
Department of Budget and Management  
**PROCUREMENT SERVICE**

**CERTIFICATE OF PHILGEPS REGISTRATION  
(Platinum Membership)**

*THIS IS TO CERTIFY THAT*

*is registered in the Philippine Government Electronic Procurement System (PhilGEPS) on 16-18th,  
2012 pursuant to Section 8.3 of the Revised Implementing Rules and Regulations of Republic Act No.  
9184, otherwise known as the Government Procurement Reform Act.*

*This further certifies that \_\_\_\_\_ has submitted the required eligibility  
documents in the PhilGEPS Supplier Registry as indicated under Annex A hereof. The Procuring Entity  
reserves the right to verify, validate and ascertain the authenticity, completeness and truthfulness of all  
the submitted documents during the post-qualification process.*

*This Certificate is valid until 30-June-2018, unless any of the documents listed under Annex A expires  
before the said date, and/or, any violation of existing laws, rules and regulations is incurred. As such,  
this Certificate shall be automatically revoked, without prejudice to the filing of applicable  
administrative, civil or criminal action.*

Issued this 30th day of January, 2017

*R. Clemente*  
**ROSA MARIA M. CLEMENTE**  
OIC, Deputy Executive Director V

Document Stamp Tax Paid Php 15.00

*[Handwritten signatures and initials at the bottom of the page]*

**Department of Trade and Industry (DTI)  
Business Name Registration**



This certifies that

\_\_\_\_\_ is a business name registered in this office pursuant to the provisions of Act 3883, as amended by Act 4147 and Republic Act No. 863, and in compliance with the applicable rules and regulations prescribed by the Department of Trade and Industry.

This certificate issued to

\_\_\_\_\_ is valid from \_\_\_\_\_ subject to continuing compliance with the above-mentioned laws and all applicable laws of the Philippines, unless voluntarily cancelled.

In testimony whereof, I hereby sign this

**Certificate of  
Business Name Registration**

and issue the same on this \_\_\_\_\_ in \_\_\_\_\_ Philippines.

  
EMMA C. ASUSANO  
DTI - NCR Regional Caretaker

Certificate No. \_\_\_\_\_

This certificate is not a license to engage in any kind of business and valid only at the place indicated herein.

TRN \_\_\_\_\_

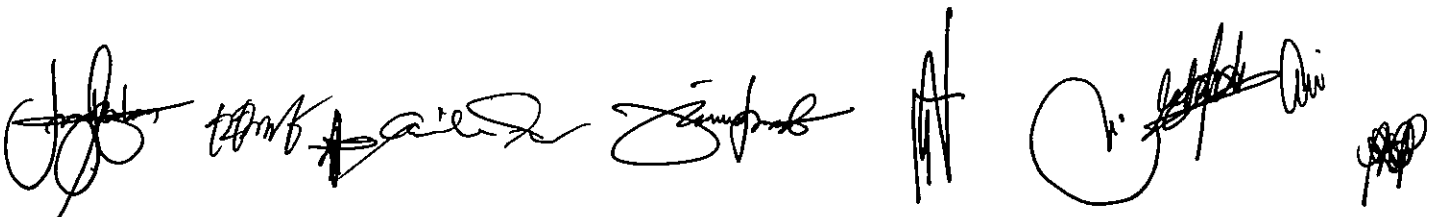

Mayor's Permit/Municipal License

Republic of the Philippines  
Province of Pampanga  
CITY OF SAN FERNANDO

FM-CSPF-BLPD-18  
Revision No. 01

CONTROL NUMBER : 9001-2011-0680  
PERMIT NUMBER : 9167  
REFERENCE NUMBER : 13-3206

MAYOR'S PERMIT

Permit is hereby granted to  
ROMAC SERVICES & TRADING COMPANY, INC.

(BUSINESS OR TRADE NAME)

MC ARTHUR HWAY, SAGUIN

LOCATION

ROMAC SERVICES & TRADING COMPANY, INC. 1

PROPRIETOR/OPERATOR/MANAGER

City of San Fernando  
Pampanga Province

2013

CERTIFIED  
2013

BUSINESS PERMIT

to engage in or operate the above mentioned business or trade activity as follows:

1. SERVICES MANPOWER SERVICES
- 2.
- 3.

The permit hereby granted is subject to all existing pertinent laws, rules and ordinances, and regulations governing the business or trade activity.

Any violation of the terms and conditions for which this permit was granted or when public interest will so require shall be enough ground to revoke the said permit and close/padlock the business establishment.

This permit is valid up to 12/31/2013 before January 20 of each year unless sooner revoked.

This permit must be displayed at all times in a conspicuous place in the business establishment. Otherwise, a fine of not less than P1,000.00 will be levied and collected.

It shall be in full force and effect on the 2nd day of January 2013 at City Of San Fernando.

143,307.30

01-24-2013

2071162

OSEAR S. RODRIGUEZ  
CITY MAYOR

Engr. Ferdinand Z. Cayson  
City Administrator

RENEWAL

MAGSILBI

Division  
Tel. No. 127 E-mail

Handwritten signatures and initials at the bottom of the page.

### Tax Clearance Certificate (for local Bidder)



REPUBLIC OF THE PHILIPPINES  
DEPARTMENT OF FINANCE  
**BUREAU OF INTERNAL REVENUE**  
**COLLECTION ENFORCEMENT DIVISION**  
National Office  
Quezon City

BIR Form. No. 17.14B

## TAX CLEARANCE

(Under Executive Order No. 398)

Name of Taxpayer

Address

Taxpayer Identification Number

Purpose

- WITH LISTED TAX LIABILITY/IES:
- NO LISTED TAX LIABILITY:
  - ▶ ISSUED BASED ON AVAILABLE RECORDS OF THE COLLECTION ENFORCEMENT DIVISION AS OF
  - ▶ BASED ON SUBMITTED DELINQUENT ACCOUNTS FROM THE REVENUE REGIONAL OFFICES & REVENUE DISTRICT OFFICES AS OF
  - ▶ ANY TAX LIABILITIES RECORDED OUTSIDE THE JURISDICTION OF THIS OFFICE IS NOT COVERED BY THIS CLEARANCE.

**TERESITA M. ANGELES**  
CHIEF, COLLECTION ENFORCEMENT DIVISION

\_\_\_\_\_  
CED File Number

\_\_\_\_\_  
(Project)

NOT VALID  
WITHOUT BIR  
DRY SEAL

J-4

NOTE: THIS CERTIFICATE SHALL BE VALID AND EFFECTIVE, ONLY WITHIN ONE (1) YEAR FROM THE DATE OF ISSUE, AND THIS SHALL NOT BE USED ON SALE/TRANSFER OF REAL PROPERTY/ES.

Paid Certification Fee P100.00 dated \_\_\_\_\_  
With attached Documentary Stamps P15.00

*[Handwritten signatures and initials at the bottom of the page]*

# Audited Financial Statement

**SUN SAVINGS BANK, INC.**  
**STATEMENTS OF FINANCIAL POSITION**

	December 31	
	2016	2015
<b>ASSETS</b>		
Cash on Hand	P14,077,841	P13,012,859
Due from Bangko Sentral ng Pilipinas (Notes 6 and 11)	220,633,625	218,210,855
Due from Other Banks (Note 6)	14,241,255	12,992,284
Available-for-Sale Investments (Note 7)	35,063,623	35,094,542
Loans and Receivables (Note 8)	565,574,779	366,849,473
Property and Equipment (Note 9)	8,760,954	10,020,438
Deferred Tax Asset (Note 19)	1,115,479	-
Other Assets (Note 10)	11,650,509	8,168,365
	<b>P871,118,065</b>	<b>P664,348,816</b>
<b>LIABILITIES AND EQUITY</b>		
<b>Liabilities</b>		
<b>Deposit Liabilities (Notes 11 and 20)</b>		
Savings	P117,483,402	P109,638,011
Current	1,200	-
Time	456,062,781	298,156,019
	<b>573,547,383</b>	<b>407,794,030</b>
Bills Payable (Note 12)	102,900,000	103,950,000
Accrued Expenses and Other Liabilities (Note 13)	10,934,358	8,343,895
Income Tax Payable	699,296	11,147
	<b>688,081,037</b>	<b>520,099,072</b>
<b>Equity</b>		
Common stock (Note 15)	175,000,000	137,500,000
Surplus	8,623,844	6,005,690
Remeasurement gain on retirement liability (Note 16)	533,379	569,498
Net unrealized gain (loss) on available-for-sale investments (Note 7)	(1,120,195)	174,556
	<b>183,037,028</b>	<b>144,249,744</b>
	<b>P871,118,065</b>	<b>P664,348,816</b>

See accompanying Notes to Financial Statements.

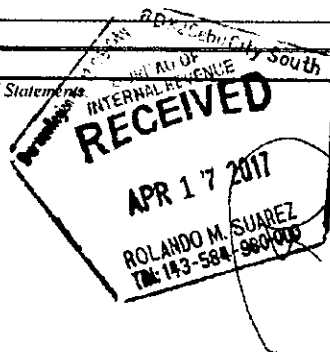

Handwritten signatures and initials are present at the bottom of the page, including several large, stylized signatures and smaller initials.

**Sample Form 6**  
**List of all Ongoing Government & Private Contracts Including Contracts Awarded but not yet Started**

**Business Name:** \_\_\_\_\_  
**Business Address:** \_\_\_\_\_

Name of Contract/ Project Cost	Owner's Name a. Address b. Telephone Nos.	Nature of Work	Bidders Role		Date Awarded		% of Accomplishment		Value of Outstanding Works/ Undelivered Portion
			Description	%	a. Date Started	b. Date of Completion	Planned	Actual	
Government									
Private									
Total Cost									

Note: This statement shall be supported with:

- 1 Notice of Award and / or Contract
- 2 Notice to Proceed issued by the Owner
- 3 Certificate of Accomplishments signed by the owner or authorized representative

Submitted by: \_\_\_\_\_  
 \_\_\_\_\_ (Printed Name and Signature)  
 Designation: \_\_\_\_\_  
 Date: \_\_\_\_\_

SUBSCRIBED AND SWORN TO before me in \_\_\_\_\_, this \_\_\_\_\_, by the undersigned who has satisfactorily proven his identity to me through his \_\_\_\_\_, valid until \_\_\_\_\_, that he is the same person who personally signed before me the foregoing affidavit and acknowledged that he executed the same

\_\_\_\_\_  
 (Notary Public)

Until \_\_\_\_\_  
 PPR No. \_\_\_\_\_  
 Date \_\_\_\_\_  
 Doc No. \_\_\_\_\_ Place \_\_\_\_\_  
 Page No. \_\_\_\_\_ TIN \_\_\_\_\_  
 Book No. \_\_\_\_\_  
 Series of \_\_\_\_\_

**Statement of Single Largest Completed Similar Contract  
Within the last five (5) years**

Project Name: \_\_\_\_\_  
 Bid Reference Nr: \_\_\_\_\_  
 Approved Budget for the Contract: \_\_\_\_\_

Statement of bidder's **Single Largest Completed Contract (SLCC)** similar to this Project, equivalent to at least at least fifty percent (50%) of the ABC of the lot/s to be bid OR at least two (2) similar contracts and the aggregate contract amounts should be equivalent to at least 50% of the ABC of the lot/s to be bid and the largest of these similar contracts should be equivalent to at least 25% of the ABC of the lot/s to be bid.

Name of Contract	Date of Contract	Kinds of Goods	Value of Contract	Status of Contract	Date of Delivery	End User's Acceptance

**The date of the contracts shall be within the last five (5) years, reckoned from the date of the Submission and Opening of Bids. The statement shall be supported by the following documents:**

For Government Contract:

1. Notice of Award/Notice to Proceed/Contract/Purchase Order issued by the end-user; and
2. Certificates of Completion and/or Technical Inspection and Acceptance Committee (TIAC) Report

For Private Contract:

3. Contract/Purchase Order issued by the end-user; and
4. Certificates of Completion and/or End-User's Acceptance or Sales Invoices/Official Receipts provided that same expressly state that the goods are received in good condition.

**Note:** For this project, Similar Contract/Project refers to:

*"Supply and Delivery of mobility equipment and/ or light to heavy construction/ engineering equipment, and/ or construction/ engineering tools and equipment, and/ or CAD software".*

Handwritten signatures and initials at the bottom of the page, including a large signature on the left, a vertical signature in the center, and several smaller signatures on the right.



Form of Bid Security:
BANK GUARANTEE

Bank Guarantee
No. \_\_\_\_\_

Name of Bidder \_\_\_\_\_ IAEB Number \_\_\_\_\_ Page \_ of \_\_\_\_.

WHEREAS, \_\_\_\_\_
(Name of Bidder)

(hereinafter called the "Bidder") has submitted his bid dated \_\_\_\_\_, for the
(Name of Project), (hereinafter called the "Bid").

KNOW ALL MEN by these presents that We \_\_\_\_\_
(Name of Bank)

of \_\_\_\_\_, having our registered office at \_\_\_\_\_
(Name of Country)

\_\_\_\_\_, (hereinafter called the "Bank,") are bound unto
(Address of Bank)
Department of National Defense (hereinafter called "the ENTITY"), in the sum of
\_\_\_\_\_, for which payment well and truly to be made
to the said ENTITY the Bank binds himself, his successor and assigns by these presents.

SEALED with the Common Seal of the said Bank this \_\_\_\_\_ day of \_\_\_\_\_ 2007.

THE CONDITIONS of this obligation are:

- 1. If the Bidder withdraws his Bid during the period of bid validity specified in the Form of Bid; or
2. If the Bidder does not accept the correction of arithmetical errors of his bid price in accordance with the Instructions to Bidder; or
3. If the Bidder having been notified of the acceptance of his bid by the Employer during the period of bid validity:
(a) fails or refuses to execute the Form of Agreement in accordance with the Instructions to Bidders, if required; or
(b) fails or refuses to furnish the Performance Security in accordance with the Instructions to Bidders.

We undertake to pay to the ENTITY up to the above amount upon receipt of his first written demand, without the ENTITY having to substantiate his demand, provided that in his demand the ENTITY will note that the amount claimed by him is due to him owing to the occurrence of one or both of the two (2) conditions, specifying the occurred condition or conditions.

The GUARANTEE will remain in force up to and including the date ONE HUNDRED TWENTY (120) CALENDAR DAYS after the deadline for submission of Bids as such deadline is in the Instructions to Bidders or as it may be extended by the ENTITY, notice of which extension(s) to the Bank is hereby waived. Any demand in respect of this Guarantee should reach the Bank not later than the above date.

DATE \_\_\_\_\_ SIGNATURE OF THE BANK \_\_\_\_\_

WITNESS \_\_\_\_\_ SEAL \_\_\_\_\_

(Signature, Name and Address)

Handwritten signatures and stamps at the bottom of the page.

IRREVOCABLE STANDBY LETTER OF CREDIT

Irrevocable Standby Letter of Credit No. \_\_\_\_\_

Name of Bidder \_\_\_\_\_ IAEB Number \_\_\_\_\_ Page \_ of \_\_\_\_.

WHEREAS, \_\_\_\_\_  
(Name and Address of Bidder)

(hereinafter called the "Bidder") has submitted his bid dated \_\_\_\_\_, for the  
\_\_\_\_\_, (hereinafter called the "Bid").  
(Name of Project)

KNOW ALL MEN by these presents that We \_\_\_\_\_  
[Name of Bank]  
of \_\_\_\_\_, having our registered office at \_\_\_\_\_  
(Name of Country)

\_\_\_\_\_, (hereinafter called the "Bank,") are bound unto  
(Address of Bank)  
Department of National Defense (hereinafter called "the ENTITY"), in the sum of  
\_\_\_\_\_, for which payment well and truly to be  
made to the said ENTITY the Bank binds himself, his successor and assigns by these presents.

SEALED with the Common Seal of the said Bank this \_\_\_\_\_ day of \_\_\_\_\_ 2007.

THE CONDITIONS of this obligation are:

1. If the Bidder withdraws his Bid during the period of bid validity specified in the Form of Bid; or
2. If the Bidder does not accept the correction of arithmetical errors of his bid price in accordance with the Instructions to Bidder; or
3. If the Bidder having been notified of the acceptance of his bid by the Employer during the period of bid validity:
  - a. fails or refuses to execute the Form of Agreement in accordance with the Instructions to Bidders, if required; or
  - b. fails or refuses to furnish the Performance Security in accordance with the Instructions to Bidders.

We undertake to pay to the ENTITY up to the above amount upon receipt of his first written demand, without the ENTITY having to substantiate his demand, provided that in his demand the ENTITY will note that the amount claimed by him is due to him owing to the occurrence of one or both of the two (2) conditions, specifying the occurred condition or conditions.

The IRREVOCABLE STANDBY LETTER OF CREDIT will remain in force up to and including the date ONE HUNDRED TWENTY (120) CALENDAR DAYS after the deadline for submission of Bids as such deadline is in the Instructions to Bidders or as it may be extended by the ENTITY, notice of which extension(s) to the Bank is hereby waived. Any demand in respect of this Guarantee should reach the Bank not later than the above date.

DATE \_\_\_\_\_ SIGNATURE OF THE BANK \_\_\_\_\_  
WITNESS \_\_\_\_\_ SEAL \_\_\_\_\_

\_\_\_\_\_  
(Signature, Name and Address)

*[Handwritten signatures and initials at the bottom of the page]*

BID SECURITY: SURETY BOND

BOND NO.: \_\_\_\_\_ DATE BOND EXECUTED: \_\_\_\_\_

By this bond, We (Name of Bidder) (hereinafter called "the Principal") as Principal and (Name of Surety) of the country of (Name of Country of Surety), authorized to transact business in the country of (Name of Country of Employer) (hereinafter called "the Surety") are held and firmly bound unto (Name of Employer) (hereinafter called "the Employer") as Obligee, in the sum of \_\_\_\_\_<sup>1</sup> for the payment of which sum, well and truly to be made, we, the said Principal and Surety bind ourselves, our successors and assigns, jointly and severally, firmly by these presents.

SEALED with our seals and dated this \_\_\_\_ day of \_\_\_\_\_ 20 \_\_\_\_\_

WHEREAS, the Principal has submitted a written Bid to the Employer dated the \_\_\_\_ day of \_\_\_\_\_ 20 \_\_\_\_\_, for the \_\_\_\_\_ (hereinafter called "the Bid").

NOW, THEREFORE, the conditions of this obligation are:

- 1) If the Principal withdraws his Bid during the period of bid validity specified in the Form of Bid; or
- 2) If the Principal does not accept the correction of arithmetical errors of his bid price in accordance with the Instruction's to Bidders: or
- 3) If the Principal having been notified of the acceptance of his Bid by the Employer during the period of bid validity:
  - a) fails or refuses to execute the Form of Agreement in accordance with the Instructions to Bidders, if required; or
  - b) fails or refuses to furnish the Performance Security in accordance with the Instructions to Bidders;

then this obligation shall remain in full force and effect, otherwise it shall be null and void.

PROVIDED HOWEVER, that the Surety shall not be:

- a) liable for a greater sum than the specified penalty of this bond, nor
- b) liable for a greater sum than the difference between the amount of the said Principal's Bid and the amount of the Bid that is accepted by the Employer.

This Surety executing this instrument hereby agrees that its obligation shall be valid for 120 calendar days after the deadline for submission of Bids as such deadline is stated in the Instructions to Bidders or as it may be extended by the Employer, notice of which extension(s) to the Surety is hereby waived.

PRINCIPAL \_\_\_\_\_ SURETY \_\_\_\_\_  
SIGNATURE(S) \_\_\_\_\_ SIGNATURE(S) \_\_\_\_\_

<sup>1</sup> The bidder should insert the amount of bond in words and figures, denominated in the currency of the Employer's country of an equivalent amount in a freely convertible currency and callable on demand. This figure should be the same as shown in the Instructions to Bidders.

*[Handwritten signatures and initials at the bottom of the page]*

BID SECURING DECLARATION

BID SECURING DECLARATION FORM

REPUBLIC OF THE PHILIPPINES
CITY OF \_\_\_\_\_, P.S.

BID SECURING DECLARATION
Invitation to Bid: [Insert Reference number]

To: [Insert name and address of the Procuring Entity]

I/We, the undersigned, declare that

- 1. I/We understand that, according to your conditions, bids must be supported by a Bid Security, which may be in the form of a Bid-Securing Declaration.
2. I/We accept that: (a) I/we will be automatically disqualified from bidding for any contract with any procuring entity for a period of two (2) years upon receipt of your Blacklisting order; and, (b) I/we will pay the applicable fine provided under Section 6 of the Guidelines on the Use of Bid Securing Declaration, within fifteen (15) days from receipt of the written demand by the procuring entity for the commission of acts resulting in the enforcement of the bid securing declaration order. Sections 23.109, 34.2, 30.1 and 32.1, except 30.1(f), of the ERR of RA 9184, without prejudice to other legal action the government may undertake.
3. I/We understand that this Bid Securing Declaration shall cease to be valid in the following circumstances:
(a) Upon expiration of the bid validity period, or any extension thereof pursuant to your request;
(b) I/we are declared ineligible or post disqualified upon receipt of your notice to such effect, and (i) I/we failed to timely file a request for reconsideration or (ii) I/we filed a waiver to avail of said right;
(c) I/we are declared the bidder with the Lowest Calculated Responsive Bid, and I/we have furnished the performance security and signed the Contract.

IN WITNESS WHEREOF, I/We have hereunto set my/our hand/s this \_\_\_ day of (month) [Insert] at [Insert] of [Insert].

[Insert NAME OF BIDDER'S AUTHORIZED REPRESENTATIVE]
[Insert Signatory's Legal Capacity]
Affiant

\*Select one and delete the other. Adopt the same provision for similar terms throughout the document.

Handwritten signatures and initials at the bottom of the page.

**NET FINANCIAL CONTRACTING CAPACITY (NFCC) STATEMENT**

The Chairperson, DND BAC 2  
Department of National Defense  
Camp General Emilio Aguinaldo  
Quezon City, Philippines

THIS IS TO CERTIFY that the attached computation of the **Net Financial Contracting Capacity (NFCC)** of

\_\_\_\_\_ of  
[Name of Bidder]  
amounting to \_\_\_\_\_ (US\$/PhP \_\_\_\_\_ )

(Amount in Words)  
as part of our submitted Class "A" Eligibility Documents (Financial) in the procurement of

\_\_\_\_\_ is true and correct.  
(Name of Project)

That this document is submitted in lieu of a commitment from a licensed bank to extend to this Company a credit line if awarded the contract, or a cash deposit certificate as required by Sec 23.11.1(3) of IRR-A of RA 9184.

Yours faithfully,  
\_\_\_\_\_  
(Name and Signature of Representative)  
\_\_\_\_\_  
(Designation)  
\_\_\_\_\_  
(Name of Firm)

SUBSCRIBED AND SWORN TO before me in \_\_\_\_\_, this \_\_\_\_\_ by the undersigned who has satisfactorily proven his identity to me through his \_\_\_\_\_ valid until \_\_\_\_\_, that he is the same person who personally signed before me the foregoing affidavit and acknowledged that he executed the same.

Notary Public  
Until 31 December 20\_\_\_\_  
PTR No. \_\_\_\_\_  
Issued at: \_\_\_\_\_  
Issued on: \_\_\_\_\_  
TIN No. \_\_\_\_\_

Doc. No. \_\_\_\_\_  
Page No. \_\_\_\_\_  
Book No. \_\_\_\_\_  
Series of \_\_\_\_\_

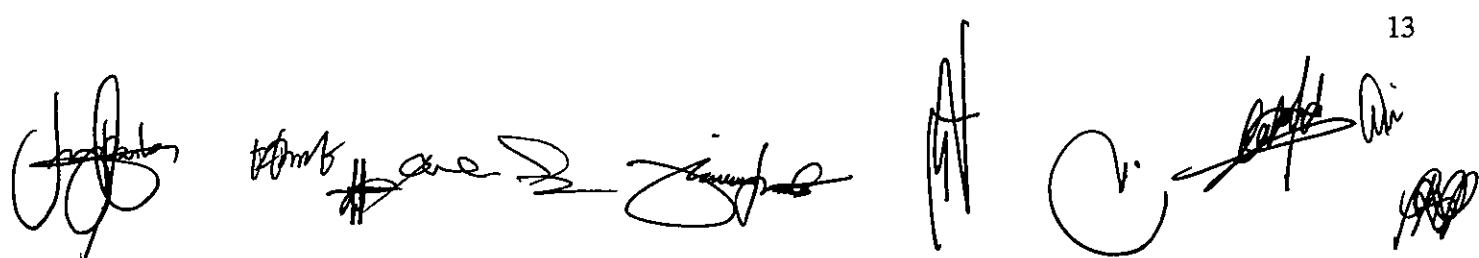

**NET FINANCIAL CONTRACTING CAPACITY (NFCC)  
COMPUTATION:**

- A. Current Assets : \_\_\_\_\_
- B. Current Liabilities : \_\_\_\_\_
- C. Project Costs:
  - 1) Outstanding : \_\_\_\_\_
  - 2) Ongoing : \_\_\_\_\_
  - 3) To Be Started : \_\_\_\_\_

Note: K = **10** for a contract duration of one year or less,  
**15** for a contract duration of more than one year up to two years,  
**20** for a contract duration of more than two years.

NFCC = \_\_\_\_\_  
[(Current Assets minus Current Liabilities) \* (K)] **minus**  
(the value of all outstanding works or projects under ongoing contracts,  
including awarded contracts yet to be started).

\_\_\_\_\_  
(Place and Date)

\_\_\_\_\_  
(Name and Signature of Representative)

\_\_\_\_\_  
(Designation)

\_\_\_\_\_  
(Name of Firm)

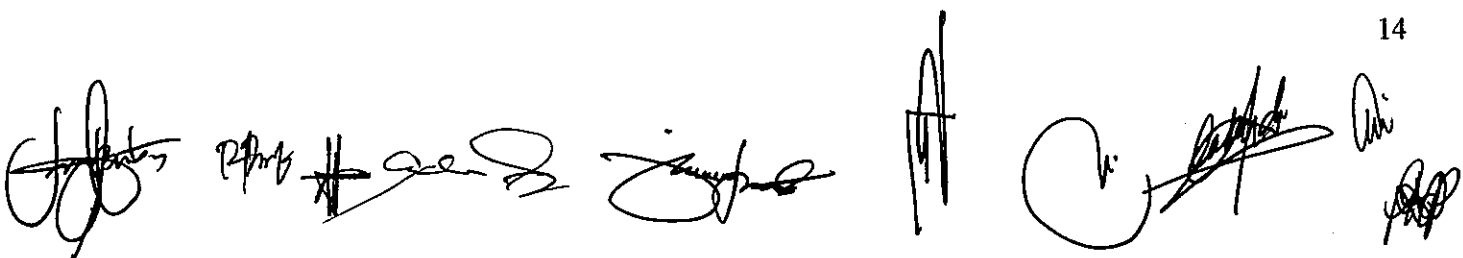

CREDIT LINE CERTIFICATE

Date: \_\_\_\_\_

The Secretary of National Defense  
Department of National Defense  
Camp General Emilio Aguinaldo  
Quezon City, Philippines

CONTRACT/PROJECT : \_\_\_\_\_  
COMPANY/FIRM : \_\_\_\_\_  
ADDRESS : \_\_\_\_\_  
BANK/FINANCING INSTITUTION : \_\_\_\_\_  
ADDRESS : \_\_\_\_\_  
AMOUNT : \_\_\_\_\_

This is to certify that the above Bank/Financing Institution with business address indicated above, commits to provide the <Contractor/Distributor/Manufacturer/Contractor>, if awarded the above-mentioned Contract, a credit line in the amount specified above which shall be exclusively used to finance the performance of the above-mentioned contract subject to our terms, conditions and requirements.

The credit line shall be available within fifteen (15) calendar days after receipt by the <Contractor/Distributor/Manufacturer/Contractor> of the Notice of Award and such line of credit shall be maintained until the project is completed by the Contractor.

This Certification is being issued in favor of said <Contractor/Distributor/Manufacturer/ Contractor> in connection with the bidding requirement of the Department of National Defense for the above-mentioned Contract. We are aware that any false statements issued by us make us liable for perjury.

Name and Signature of Authorized  
Financing Institution Officer : \_\_\_\_\_  
Official Designation : \_\_\_\_\_

Concurred By:  
Name & Signature of Contractor/Distributor/  
/Manufacturer's Authorized Representative : \_\_\_\_\_  
Official Designation : \_\_\_\_\_

Note:  
The amount committed should be machine validated.

SUBSCRIBED AND SWORN TO before me in \_\_\_\_\_, this \_\_\_\_\_ by the undersigned who has satisfactorily proven his identity to me through his \_\_\_\_\_ valid until \_\_\_\_\_, that he is the same person who personally signed before me the foregoing affidavit and acknowledged that he executed the same.

Notary Public  
Until 31 December 20\_\_\_\_  
PTR No. \_\_\_\_\_  
Issued at: \_\_\_\_\_  
Issued on: \_\_\_\_\_  
TIN No. \_\_\_\_\_

Doc. No. \_\_\_\_\_  
Page No. \_\_\_\_\_  
Book No. \_\_\_\_\_  
Series of \_\_\_\_\_

*[Handwritten signatures and initials at the bottom of the page]*

JOINT VENTURE AGREEMENT

KNOW ALL MEN BY THESE PRESENTS:

That this JOINT VENTURE AGREEMENT is entered into By and Between \_\_\_\_\_ of legal age, \_\_\_\_\_ (Civil Status) owner/proprietor of \_\_\_\_\_ and a resident of \_\_\_\_\_ - and - \_\_\_\_\_ of legal age, \_\_\_\_\_ (Civil Status) owner/proprietor of \_\_\_\_\_ and a resident of \_\_\_\_\_

THAT both parties agree to join together their manpower, equipment, and what is needed to facilitate the Joint Venture to participate in the Eligibility, Bidding and Undertaking of the here-under stated project/s to be conducted by the Department of National Defense:

(Name of Project)

That both parties agree to be jointly and severally liable for the entire agreement.

That both parties agree that \_\_\_\_\_ and/or \_\_\_\_\_, shall be the Official Representative of the Joint Venture, and is granted full power and authority to do, execute and perform any and all acts necessary and/or to represent the Joint Venture in the bidding as fully and effectively and the Joint Venture may do and if personally present with full power of substitution and revocation.

That this Joint Venture Agreement shall remain in effect only for the above stated Project/s until terminated by both parties.

Done this \_\_\_\_\_ day of \_\_\_\_\_, in \_\_\_\_\_.

(Name and Signature of JV Partner)

(Name and Signature of JV Partner)

ACKNOWLEDGMENT

\_\_\_\_\_ ) \_\_\_\_\_ ) SS.

Before me, a Notary Public for and in \_\_\_\_\_, this \_\_\_ day of \_\_\_\_\_, 2008 appeared the following persons presenting to me their respective identifications, to wit:

Passport No./CTC No.

Issued at

Expiry date

known to me and to me known to be the same persons who executed and voluntarily signed the foregoing Contract which they acknowledged before me as their own free and voluntary act and deed with full authority to sign in that capacity.

WITNESS MY HAND AND SEAL, on the date and place above written.

Doc. No. \_\_\_\_\_; Page No. \_\_\_\_\_; Book No. \_\_\_\_\_; Series of 2007

Handwritten signatures and initials at the bottom of the page.



Omnibus Sworn Statement

REPUBLIC OF THE PHILIPPINES )  
CITY/MUNICIPALITY OF \_\_\_\_\_) S.S.

**AFFIDAVIT**

I, [Name of Affiant], of legal age, [Civil Status], [Nationality], and residing at [Address of Affiant], after having been duly sworn in accordance with law, do hereby depose and state that:

**1. Select one, delete the other:**

*If a sole proprietorship:* I am the sole proprietor of [Name of Bidder] with office address at [address of Bidder];

*If a partnership, corporation, cooperative, or joint venture:* I am the duly authorized and designated representative of [Name of Bidder] with office address at [address of Bidder];

**2. Select one, delete the other:**

*If a sole proprietorship:* As the owner and sole proprietor of [Name of Bidder], I have full power and authority to do, execute and perform any and all acts necessary to represent it in the bidding for [Name of the Project] of the [Name of the Procuring Entity];

*If a partnership, corporation, cooperative, or joint venture:* I am granted full power and authority to do, execute and perform any and all acts necessary and/or to represent the [Name of Bidder] in the bidding as shown in the attached [state title of attached document showing proof of authorization (e.g., duly notarized Secretary's Certificate issued by the corporation or the members of the joint venture)];

3. [Name of Bidder] is not "blacklisted" or barred from bidding by the Government of the Philippines or any of its agencies, offices, corporations, or Local Government Units, foreign government/foreign or international financing institution whose blacklisting rules have been recognized by the Government Procurement Policy Board;
4. Each of the documents submitted in satisfaction of the bidding requirements is an authentic copy of the original, complete, and all statements and information provided therein are true and correct;
5. [Name of Bidder] is authorizing the Head of the Procuring Entity or its duly authorized representative(s) to verify all the documents submitted;

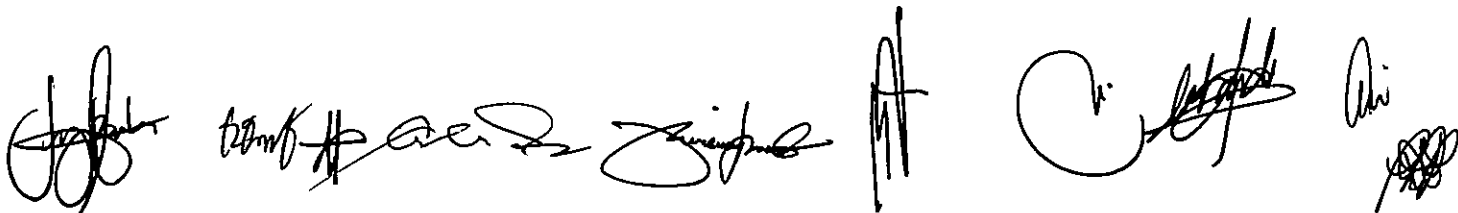

6. **Select one, delete the rest:** *If a sole proprietorship:* I am not related to the Head of the Procuring Entity, members of the Bids and Awards Committee (BAC), the Technical Working Group, and the BAC Secretariat, the head of the Project Management Office or the end-user unit, and the project consultants by consanguinity or affinity up to the third civil degree;

*If a partnership or cooperative:* None of the officers and members of [Name of Bidder] is related to the Head of the Procuring Entity, members of the Bids and Awards Committee (BAC), the Technical Working Group, and the BAC Secretariat, the head of the Project Management Office or the end-user unit, and the project consultants by consanguinity or affinity up to the third civil degree;

*If a corporation or joint venture:* None of the officers, directors, and controlling stockholders of [Name of Bidder] is related to the Head of the Procuring Entity, members of the Bids and Awards Committee (BAC), the Technical Working Group, and the BAC Secretariat, the head of the Project Management Office or the end-user unit, and the project consultants by consanguinity or affinity up to the third civil degree;

7. [Name of Bidder] complies with existing labor laws and standards; and

8. [Name of Bidder] is aware of and has undertaken the following responsibilities as a Bidder:

- a) Carefully examine all of the Bidding Documents;
- b) Acknowledge all conditions, local or otherwise, affecting the implementation of the Contract;
- c) Made an estimate of the facilities available and needed for the contract to be bid, if any; and
- d) Inquire or secure Supplemental/Bid Bulletin(s) issued for the [Name of the Project].

9. [Name of Bidder] did not give or pay directly or indirectly, any commission, amount, fee or any form of consideration, pecuniary or otherwise, to any person or official, personnel or representative of the government in relation to any procurement project or activity.

IN WITNESS WHEREOF, I have hereunto set my hand this \_\_\_day of \_\_\_, 20\_\_ at \_\_\_\_\_, Philippines.

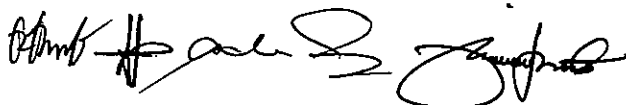
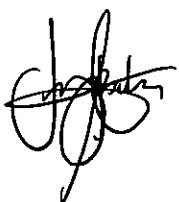

Bidder's Representative/Authorized Signatory

**SUBSCRIBE AND SWORN** to before me this \_\_\_ day of [month] [year] at [place of execution], Philippines. Affiant/s is/are personally known to me and was/were identified by me through competent evidence of identity as defined in the 2004 Rules of Notarial Practice (A.M. No 02-8-13-SC). Affiant/s exhibited to me his/her [insert type of government identification card used], with his/her photograph and signature appearing thereon, with no. \_\_\_\_\_ and his/her \_\_\_\_\_ issued on \_\_\_\_\_ at \_\_\_\_\_.

Witness my hand and seal this \_\_\_\_\_ day of [month] [year]

**NAME OF NOTARY PUBLIC**

Serial No. of Commission \_\_\_\_\_

Notary Public for \_\_\_\_\_ until \_\_\_ Roll

of Attorneys No. \_\_\_\_\_

PTR No. \_\_\_\_\_ [date issued], [place issued]

IBP No. \_\_\_\_\_ [date issued], [place issued]

Doc No. \_\_\_\_\_

Page No. \_\_\_\_\_

Book No. \_\_\_\_\_

Series No. \_\_\_\_\_

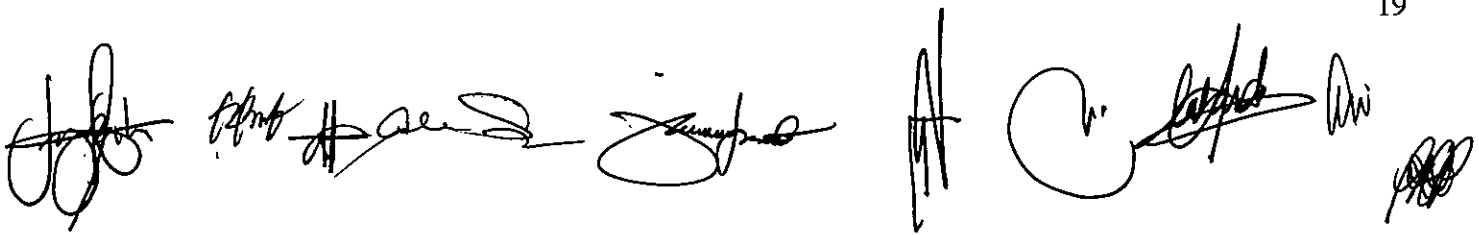
The bottom of the page contains several handwritten signatures and stamps. From left to right, there is a large, stylized signature, followed by a smaller signature, then another signature, a vertical stamp, a circular stamp, and finally a signature with a date '2011' written next to it. There is also a small, illegible stamp at the far right.

**Brand New Equipment Certification**

The Chairperson, DND BAC 2  
Department of National Defense  
Camp General Emilio Aguinaldo  
Quezon City, Philippines

I, \_\_\_\_\_, the duly authorized representative of \_\_\_\_\_ do hereby certify that all equipment to be supplied are brand new and manufactured within the last 12 months from issuance of NTP

This certification is submitted as part of our Class "A" Eligibility Documents in the procurement of \_\_\_\_\_  
(Name of Project)

Yours faithfully,

\_\_\_\_\_  
(Name and Signature of Representative)

\_\_\_\_\_  
(Designation)

\_\_\_\_\_  
(Name of Firm)

SUBSCRIBED AND SWORN TO before me in \_\_\_\_\_, this \_\_\_\_\_ by the undersigned who has satisfactorily proven his identity to me through his \_\_\_\_\_ valid until \_\_\_\_\_, that he is the same person who personally signed before me the foregoing affidavit and acknowledged that he executed the same.

\_\_\_\_\_  
(Notary Public)

Until \_\_\_\_\_  
PTR No. \_\_\_\_\_  
Date \_\_\_\_\_  
Place \_\_\_\_\_  
TIN \_\_\_\_\_

Doc No. \_\_\_\_\_  
Page No. \_\_\_\_\_  
Book No. \_\_\_\_\_  
Series of \_\_\_\_\_

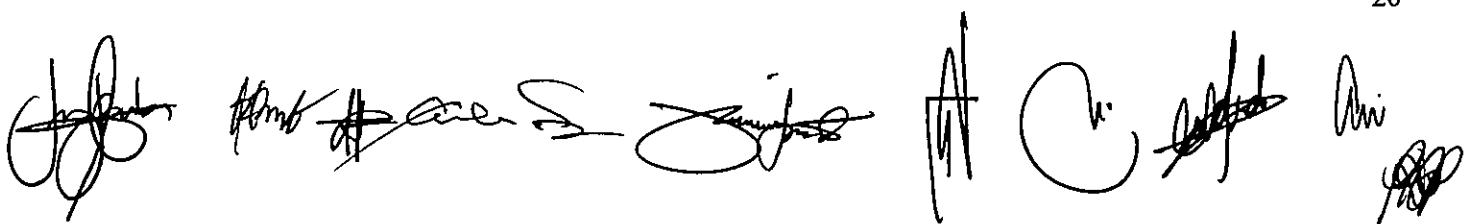

ISO 9001:2015 Certificates of  
Manufacturer

# Certificate

This is to Certify that

**Organization Name**

**Organization Address**

**This is Draft Certificate Only**

Compliance with  
**Quality Management System**

## ISO 9001:2015

for the following scope:

**Scope of Organization**

Certificate No.

Original Certificate Date:

Issue Date

Expiry Date

To check this certificate status visit:  
<http://www.uk.com/certifiedorganization.html>



Authorized Signature

**For Quality Control Certification**

Head Office: 2nd Floor, Aman Market,

Marela Mansi, Delhi - 110 040, India

UK Office: 1920, Chrysoth House,

Troviscome Park, Teuro - TR4 8UN,

Cornwall, UK



Quality Control Certification is certified by UKCC, UK.  
This certificate does not guarantee the certified organization with immunity from its legal obligations.  
This certificate reserves the authority of UKCC Certification to annul it if found to be invalid or illegal.

*[Handwritten signatures and scribbles at the bottom of the page]*

Certificate of Distributorship



Certificate of Distributorship 2017

We of GESCHA Absauganlagen und Umwelttechnik GmbH,  
Manufacturer of Spray booths and Paint Equipments  
do hereby certify that

**NAME OF THE COMPANY**

*located at*

ADDRESS OF THE COMPANY

*Is an authorized distributor of GESCHA*



Issue Date:

Certificate No. D

Michael Schaber, CEO

*[Handwritten signatures and initials at the bottom of the page]*

**Certificate of availability of Service Centers**  
in Luzon, Visayas and Mindanao

The Chairperson, DND BAC 2  
Department of National Defense  
Camp General Emilio Aguinaldo  
Quezon City, Philippines

I, \_\_\_\_\_, the duly authorized representative of

ABC Construction Eqpmt do hereby certify that we have at least one (1) service center of **the same name/ or subsidiary company** each for Luzon, Visayas and Mindanao as indicated below:

Location/ Address	Business name	Contact Nrs/ website
1. <u>Murphy St, Cubao, Q.C.</u>	<u>ABC Construction Eqpmt</u>	<u>+63123456789</u>
2. <u>Lapu-lapu St, Cebu City</u>	<u>ABC Construction Eqpmt</u>	<u>+63987654321</u>
3. <u>Fernando St. Davao City</u>	<u>XYZ Construction Eqpmt</u>	<u>+63xxxxxxxxxxx</u>

Attached herewith are proof that XYZ Construction Eqpmt with business address at Fernando St. Davao City is a subsidiary of or company owned and controlled by ABC Construction Eqpmt.

This certification is submitted as part of our Class "A" Eligibility Documents in the procurement of \_\_\_\_\_.  
(Name of Project)

Yours faithfully,

\_\_\_\_\_  
(Name and Signature of Representative)

\_\_\_\_\_  
(Designation)

\_\_\_\_\_  
(Name of Firm)

STATEMENT OF UNDERTAKING

Availability of at least three (3) mobile field after sales service teams with nationwide coverage and 1-yr on-site free servicing

The Chairperson, DND BAC 2
Department of National Defense
Camp General Emilio Aguinaldo, Quezon City, Philippines

I, \_\_\_\_\_, the duly authorized representative of \_\_\_\_\_ do hereby certify that we have at least three (3) mobile field after sales service teams with nationwide coverage as indicated below:

Table with 3 columns: Location (base), Business name, Contact Nrs/ website. Rows 1, 2, 3.

I also certify for one (1) year upon acceptance free on-site PMS and repair (parts, consumables, labor & fares) for the \_\_\_\_\_ offered

This certification is submitted as part of our Class "A" Eligibility Documents in the procurement of \_\_\_\_\_ (Name of Project)

Yours faithfully,

(Name and Signature of Representative)

(Designation)

(Name of Firm)

SUBSCRIBED AND SWORN TO before me in \_\_\_\_\_, this \_\_\_\_\_ by the undersigned who has satisfactorily proven his identity to me through his \_\_\_\_\_ valid until \_\_\_\_\_, that he is the same person who personally signed before me the foregoing affidavit and acknowledged that he executed the same.

(Notary Public)

Until \_\_\_\_\_
PTR No. \_\_\_\_\_
Date \_\_\_\_\_
Place \_\_\_\_\_
TIN \_\_\_\_\_

Doc No. \_\_\_\_\_
Page No. \_\_\_\_\_
Book No. \_\_\_\_\_
Series of \_\_\_\_\_

Handwritten signatures and initials at the bottom of the page.



MILL CERTIFICATE

MTC-ASTM A588 Steel Plate

Apr 01 2016

质量证明书

MILL TEST CERTIFICATE



订货单位/CONSIGNEE: 产品名称/COMMODITY: 产品规格/ITEM NUMBER: 本公司地址/ADDRESS: 1000 惠康体育中心  
 日期/DATE: 2015-06-15 产品规格/ITEM NUMBER: 批准/ APPROVED BY: 1509090112000  
 合同号/CONTRACT NO.: 11001100112 牌号/STEEL GRADE: ASTM A588 编号/NO.: 01A015

卷号 AKT NO.	炉号 HEAT NO.	重量 WTG HT	化学成分 CHEMICAL COMPOSITION %								机械性能 MECHANICS CAPABILITY		
			C	SI	MN	P	S	CR	N	CU	抗拉强度 TENSILE STRENGTH (Mpa)	屈服强度 YIELD STRENGTH (Mpa)	伸长率 ELONG STRENGTH ATION %
SECTION	SPH312	150MT	<0.19	0.20-0.45	0.00-1.25	0.0041	0.005	0.00-0.55	0.003	0.25-0.30	415-485	290-345	219
合计 TOTAL	150MT		交货状态 DELIVERY CONDITION								交货状态 SERVACE CONDITION		
			HOT ROLLED				AS-ROLL				交货状态 QUALITY OF CERTIFICATE		

请保持干燥, 使用前先要验证, 如有异议请向供货方并来函通知, TEST BEFORE USE, IF YOU HAVE ANY OTHER REQUESTS, PLEASE TELL US IN ADVANCE.  
 2. 如有其它要求或需服务, 请来信或电: YOU HAVE OTHER REQUEST AND SERVICE, PLEASE TELL US IN ADVANCE.  
 检验员/INSPECTOR: 刘利 审核员/AUDITOR: 李林 材料员/MATERIAL: 李林  
 惠康体育中心有限公司  
 1000 惠康体育中心  
 1000 惠康体育中心

MTC-ASTM A588 Steel Plate

Note: The Mill certificate must be traceable to the "frame/ chassis" material of the product (OEM) offered

Handwritten signatures and marks at the bottom of the page, including a large signature on the left and several smaller ones on the right.

**Manufacturer/ Distributor's Warranty Certificate**

The Chairperson, DND BAC 2  
Department of National Defense  
Camp General Emilio Aguinaldo  
Quezon City, Philippines

I, \_\_\_\_\_, the duly authorized representative of \_\_\_\_\_ warrants that the Goods supplied are free from defects for a period of at least one (1) year from acceptance. All faulty parts and/or functions during the warranty period resulting despite user's normal use, will be repaired and/or replaced at no charge.

This certification is submitted as part of our Class "A" Eligibility Documents in the procurement of \_\_\_\_\_.  
(Name of Project)

Yours faithfully,

\_\_\_\_\_  
(Name and Signature of Representative)

\_\_\_\_\_  
(Designation)

\_\_\_\_\_  
(Name of Firm)

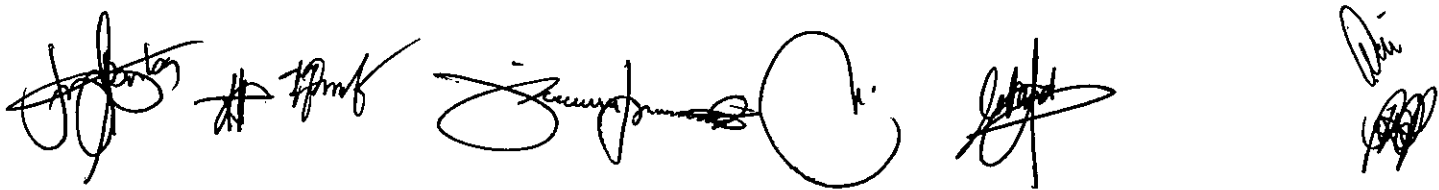
A series of handwritten signatures and initials are located at the bottom of the page. From left to right, there are approximately six distinct marks, including a large signature, several initials, and a signature on the far right.

**Sample Form 23**

**Statement of Compliance to Schedule of Requirements**

(kindly refer to Sec. VI of this Bidding Documents)

*[Handwritten signatures and initials]*

**Statement of Compliance to Technical Specifications**

(kindly refer to Sec. VII of this Bidding Documents)

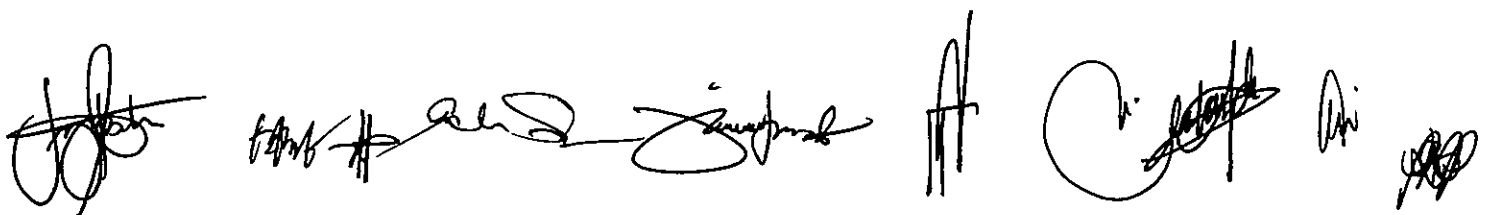
A series of handwritten signatures and initials in black ink, including a large signature on the left, a signature in the middle, and several initials on the right.

Brochures

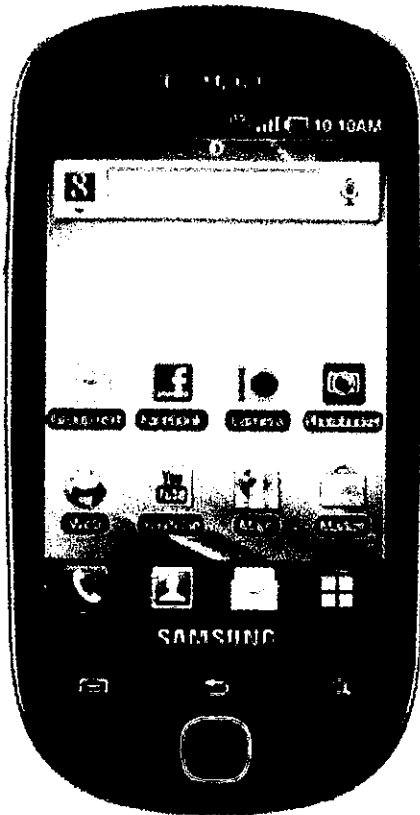

## Samsung Gravity SMART

### KEY FEATURES

QWERTY Keyboard

3.15 MP, 2048x1536 pixels, LED flash

microSD, up to 32GB, 2 GB included

WLAN Wi-Fi 802.11 b/g, DLNA, Wi-Fi hotspot

OS Android OS, v2.2 (Froyo)

Google Search, Maps, Gmail, YouTube, Calendar, Google Talk, Picasa integration

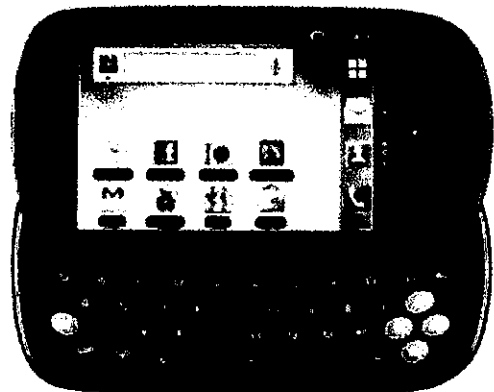

### FEATURES

#### Operating Frequency

2G Network GSM 850 / 900 / 1800 / 1900  
3G Network HSDPA 1700 / 2100

OS Android OS, v2.2 (Froyo)  
CPU 800 MHz ARMv6  
Sensors Accelerometer, proximity

#### Dimensions

Dimensions 114 x 59 x 14 mm  
Weight 130 g  
Keyboard QWERTY  
Touch-sensitive controls

#### Display

Size 3.2 inches (~180 ppi pixel density)  
320 x 480 pixels  
TFT capacitive touchscreen, 16M colors  
Multitouch Yes  
TouchWiz 3.0 UI

#### Memory

microSD, up to 32GB, 2 GB included  
Internal 150 MB storage, 270 MB RAM

#### Battery

Standard battery, Li-Ion 1500 mAh  
Stand-by Up to 364 h  
Talk time Up to 5 h 30 min

#### Camera

CAMERA 3.15 MP, 2048x1536 pixels, LED flash  
Features Geo-tagging  
Video Yes, QVGA @ 14fps  
Secondary No

#### Sound

Loud speaker/3.5mm jack  
MP4/H.264/H.263 player  
MP3/WAV/AAC+ player

*[Handwritten signatures and scribbles at the bottom of the page]*

# Duly Signed Drawings

## 1. 1.5cu.m Fuel Dolly

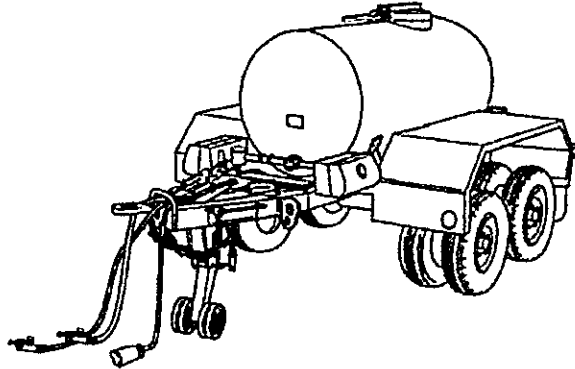

Note: "Single Axle" only

## 2. 1.5cu.m Water Dolly

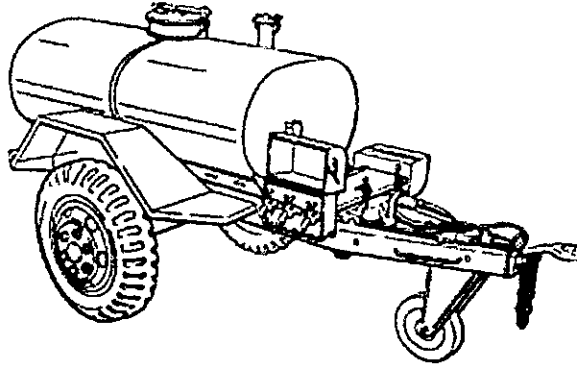

## 3. 40ft Skeletal Semi-Trailers

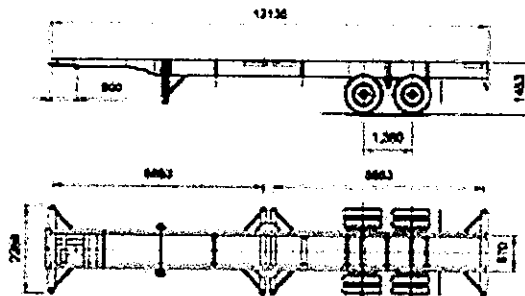

40' SKELETAL TRAILER (S.B.I. 41)

## 4. 20ft Skeletal Semi-Trailers

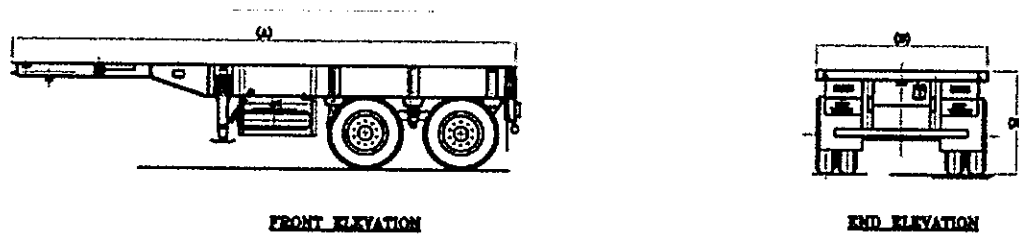

FRONT ELEVATION

END ELEVATION

*[Handwritten signatures and initials]*

Duly Signed Drawings

5. 40ft Remodeled HC Container Vans

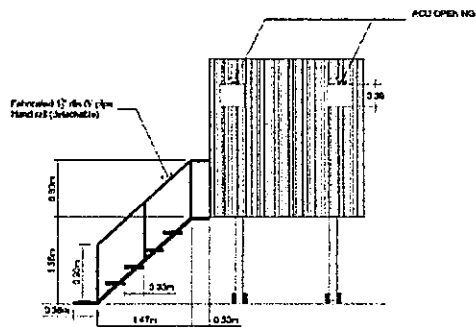
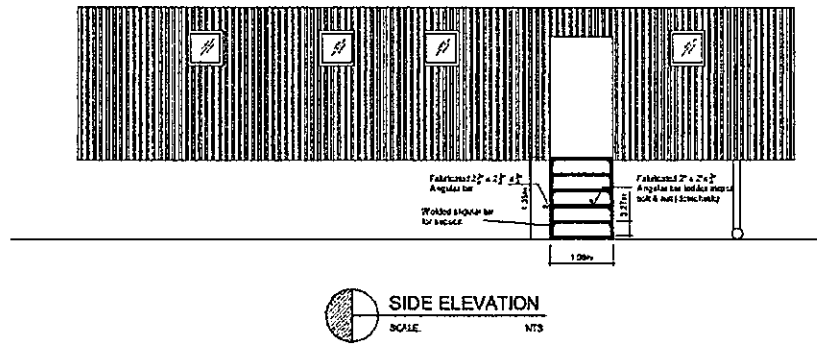
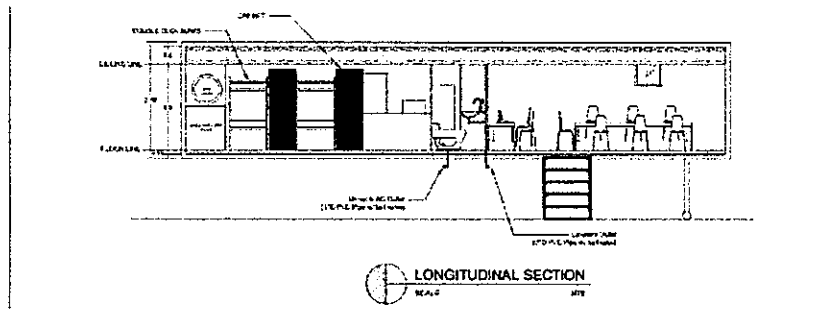
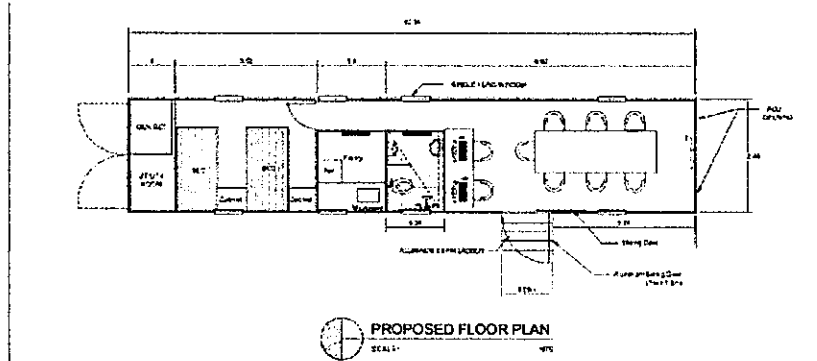

Inlet (3"Ø PVC pipe w/ Ball Valve)  
Outlet (3"Ø PVC pipe w/ Ball Valve)

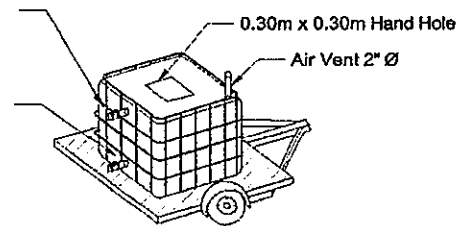

DETACHABLE SEPTIC VAULT DETAIL  
SCALE: NTS

*[Handwritten signatures and initials]*

# Duly Signed Drawings

## 6. 10ft Remodeled HC Container Vans

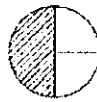
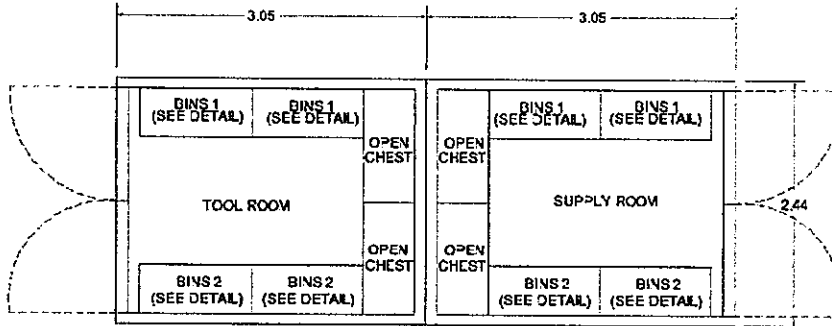

PROPOSED FLOOR PLAN

SCALE:

NTS

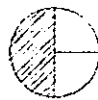
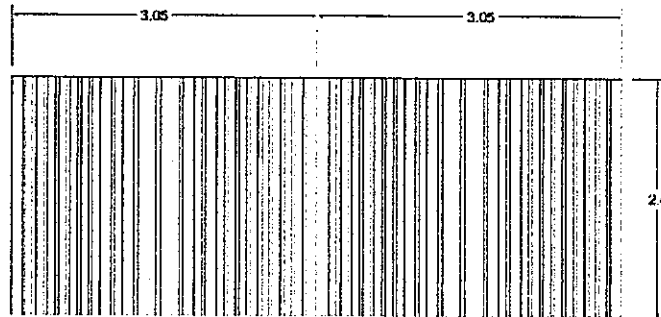

ELEVATION

SCALE:

NTS

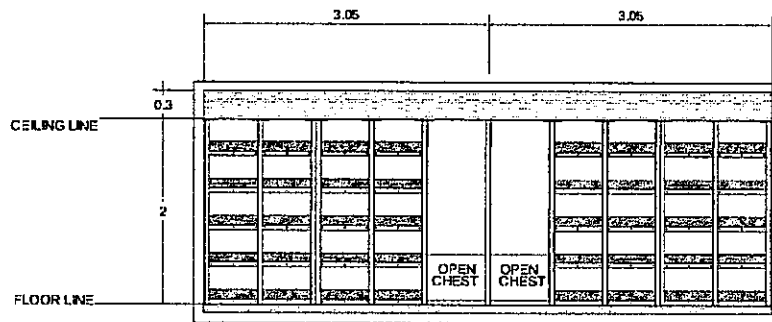

LONGITUDINAL SECTION

SCALE:

NTS

*[Handwritten signatures and initials]*



### Duly Signed Drawings

#### 7. Tents (4m x 8m), 8 sets

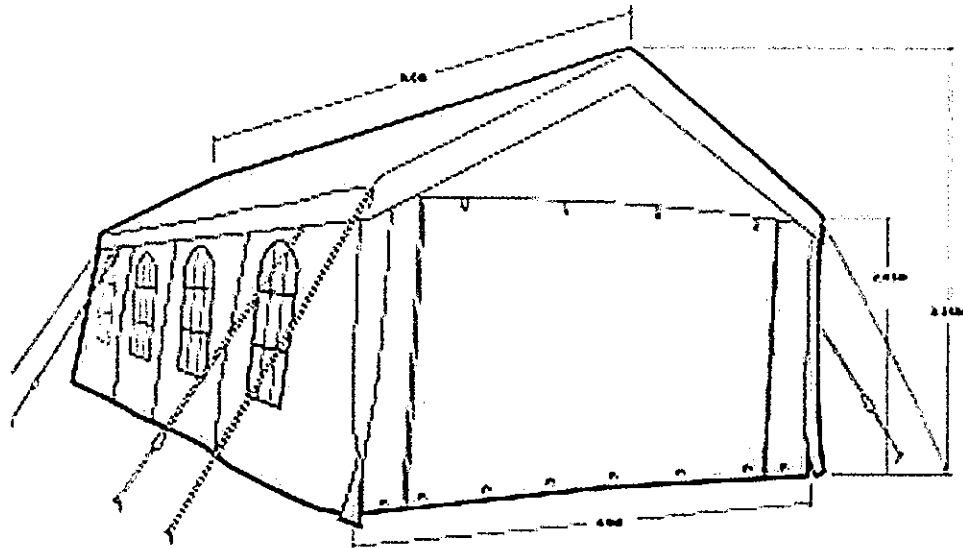

#### 8. Double decked steel bunks, 64 units

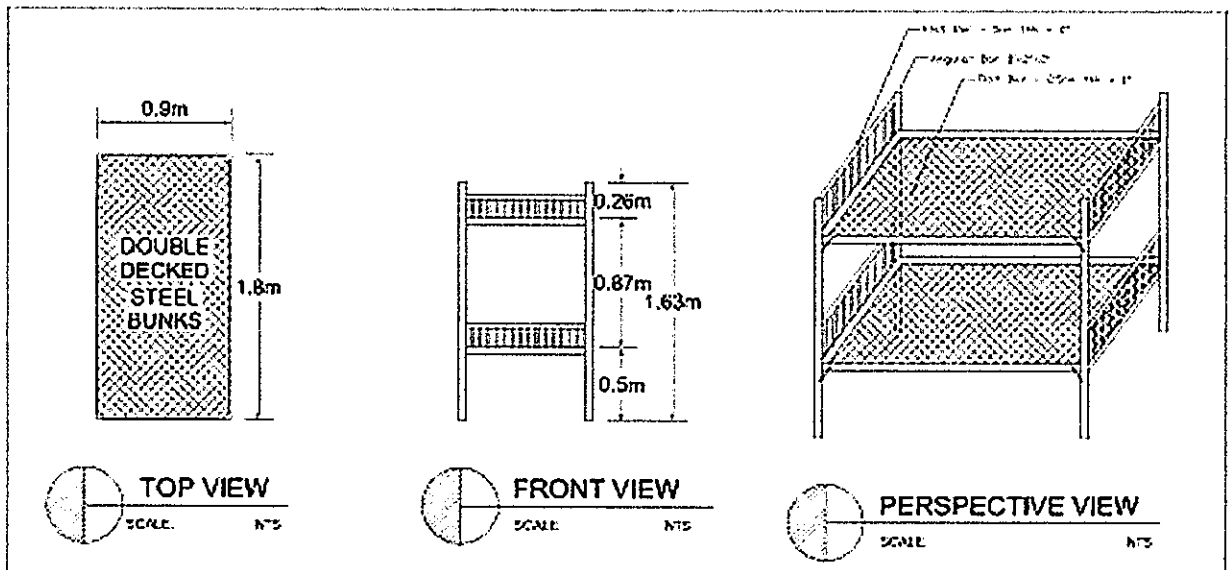

*[Handwritten signatures and initials]*

# Duly Signed Drawings

## 9. Racks & Shelves of 17' Alum Van

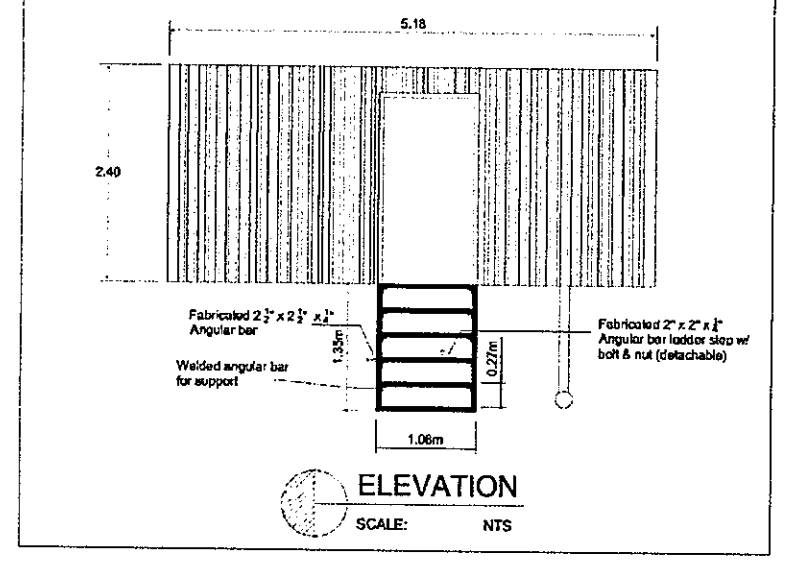
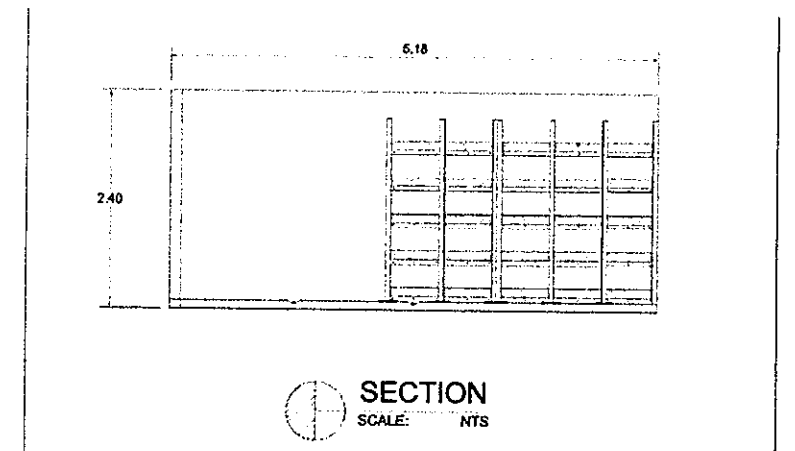
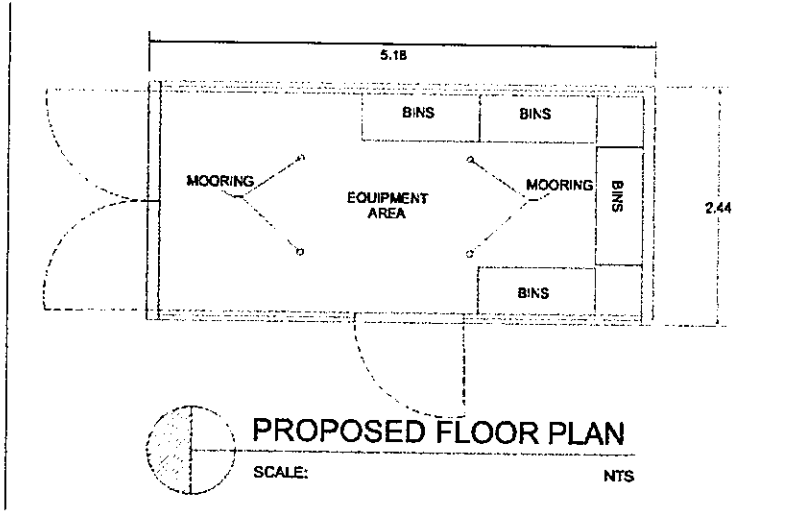

*[Handwritten signatures and initials]*



LETTER OF UNDERTAKING

The Secretary of National Defense
Department of National Defense
Camp General Emilio Aguinaldo
Quezon City, Philippines

THIS IS TO CERTIFY that the following shall be made available by [Name of Bidder] on demand by the PURCHASER, as part of our submitted Class "A" Eligibility Documents (Technical) in the procurement of Philippine Air Force Aviation Engineering Equipment Lot Nrs 3, 4 & 10 to 19:

- a. Spare Parts for at least 15 years, after the final acceptance;
b. Technical/ consultative support for at least 15 years, after the final acceptance;
c. Technical Representatives upon notification/request;

This certification is submitted as part of our Class "A" Eligibility Documents in the procurement of (Name of Project)

Yours faithfully,

(Name and Signature of Representative)
(Designation)
(Name of Firm)

SUBSCRIBED AND SWORN TO before me in this by the undersigned who has satisfactorily proven his identity to me through his valid until that he is the same person who personally signed before me the foregoing affidavit and acknowledged that he executed the same

Notary Public
Until 31 December 20
PTR No.
Issued at:
Issued on:
TIN No.

Doc. No.
Page No.
Book No.
Series of

Handwritten signatures and initials at the bottom of the page.

LETTER OF UNDERTAKING

The Secretary of National Defense
Department of National Defense
Camp General Emilio Aguinaldo
Quezon City, Philippines

THIS IS TO CERTIFY that the following shall be made available by [Name of Bidder] on demand by the PURCHASER, as part of our submitted Class "A" Eligibility Documents (Technical) in the procurement of Philippine Air Force Aviation Engineering Equipment Lot Nrs 7, 21, 25, 27, 28, 30 & 32:

- a. Spare Parts for at least 10 years, after the final acceptance;
b. Technical/ consultative support for at least 10 years, after the final acceptance;
c. Technical Representatives upon notification/request;

This certification is submitted as part of our Class "A" Eligibility Documents in the procurement of (Name of Project)

Yours faithfully,

(Name and Signature of Representative)

(Designation)

(Name of Firm)

SUBSCRIBED AND SWORN TO before me in this identity to me through his valid until that he is the same person who personally signed before me the foregoing affidavit and acknowledged that he executed the same

Notary Public
Until 31 December 20
PTR No.
Issued at:
Issued on:
TIN No.

Doc. No.
Page No.
Book No.
Series of

Handwritten signatures and stamps at the bottom of the page.

LETTER OF UNDERTAKING

The Secretary of National Defense
Department of National Defense
Camp General Emilio Aguinaldo
Quezon City, Philippines

THIS IS TO CERTIFY that the following shall be made available by [Name of Bidder] on demand by the PURCHASER, as part of our submitted Class "A" Eligibility Documents (Technical) in the procurement of Philippine Air Force Aviation Engineering Equipment Lot Nrs 2 & 31:

- a. Spare Parts for at least 5 years, after the final acceptance;
b. Technical/ consultative support for at least 5 years, after the final acceptance;
c. Technical Representatives upon notification/request;

This certification is submitted as part of our Class "A" Eligibility Documents in the procurement of (Name of Project)

Yours faithfully,

(Name and Signature of Representative)
(Designation)
(Name of Firm)

SUBSCRIBED AND SWORN TO before me in this identity to me through his valid until that he is the same person who personally signed before me the foregoing affidavit and acknowledged that he executed the same

Notary Public
Until 31 December 20
PTR No.
Issued at:
Issued on:
TIN No.

Doc. No.
Page No.
Book No.
Series of

Handwritten signatures and initials at the bottom of the page.

Sample Form (Financial Proposal)

Price Proposal

Date: \_\_\_\_\_
IAEB No: \_\_\_\_\_

The Secretary of National Defense
Department of National Defense
Camp Gen Emilio Aguinaldo
Quezon City

Attention: The Chairman
DND Bids and Awards Committee

Gentlemen:

Having examined the Bidding Documents including Bid Bulletin Numbers
[insert numbers], the receipt of which is hereby
duly acknowledged, we, the undersigned, offer to
[supply/deliver]
[description of the GOODS] in conformity with the said Bidding Documents for the sum of
[total Bid amount in words and figures] or such other sums as may be ascertained
in accordance with the Schedule of Prices attached herewith and made part of this Bid.

We undertake, if our Bid is accepted, to deliver the goods in accordance with the delivery
schedule specified in the Schedule of Requirements.

If our Bid is accepted, we undertake to provide a performance security in the form,
amounts, and within the times specified in the Bidding Documents.

We agree to abide by this Bid for the Bid Validity Period specified in BDS provision for ITB
Clause 22.2 and it shall remain binding upon us and may be accepted at any time before the
expiration of that period.

Commissions or gratuities, if any, paid or to be paid by us to agents relating to this Bid,
and to contract execution if we are awarded the contract, are listed below:

Table with 3 columns: Name and address of Agent, Amount and Currency, Purpose of Commission or Gratuity

(if none, state "None")

Until a formal Contract is prepared and executed, this Bid, together with your written
acceptance thereof and your Notice of Award, shall be binding upon us.

We understand that you are not bound to accept the lowest or any Bid you may receive.

We certify/confirm that we comply with the eligibility requirements as per ITB Clause 5 of
the Bidding Documents.

Dated this \_\_\_\_\_ day of \_\_\_\_\_ 20\_\_\_\_\_

[signature] [in the capacity of]
Duly authorized to sign Bid for and on behalf of \_\_\_\_\_

Instructions:

- 4. The price shall be quoted only in Philippine Pesos. The price per line item shall be quoted.
5. The bidder shall indicate the cost for each item no more than two decimal places. Should the figures exceed two decimal places, rounding off based on the rules of mathematics shall be applied.
6. In case of discrepancies between: (a) prices in words and figures, the price in words shall prevail; (b) total prices and unit prices, the latter shall prevail; and (c) unit cost in the detailed estimate and unit cost in the bill of quantities, the latter shall prevail.
7. The name of the firm, business address, authorized signatory and authorized signature shall be duly

**For Goods Offered From Abroad**

**Sample Form (Financial Proj**

Name of Bidder           , IAEB Number           , Page        of       .

*(Handwritten mark)*

1	2	3	4	5	6
Item Nr	Description	Country of Origin	Quantity	Unit Price Delivered at Place (DAP)	Total Price Delivered at Place (DAP) (Col 4 x 5)

\_\_\_\_\_  
**Name and Signature of the B**

**Note:** In case of discrepancy between unit price and total, the unit price shall p

\_\_\_\_\_

DND Bids and Awards Committee, Department of National Defense, DND Building, Camp General Banilio Aguinaldo, Quezon City  
☎ DND TWG - 4212202; BAC Secretariat - 4213531

*(Handwritten signatures)*